

# これが ファミリーコンピュータだ!!

ディスクシステム編



**Nintendo®**

TRANSLATED BY ZUMI & NFG  
NFGGAMES.COM **NFG**  
GAMES



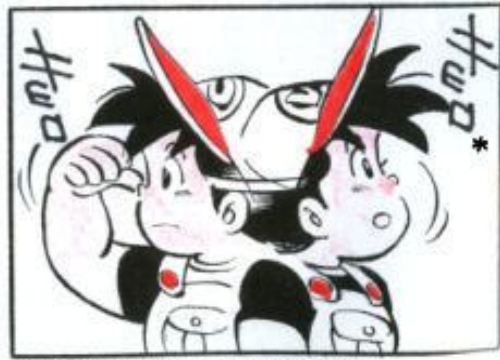
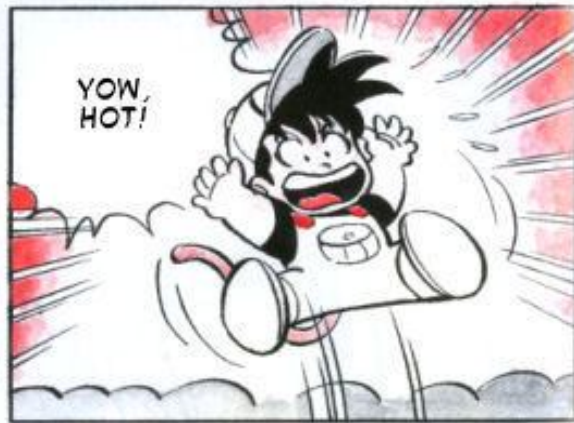
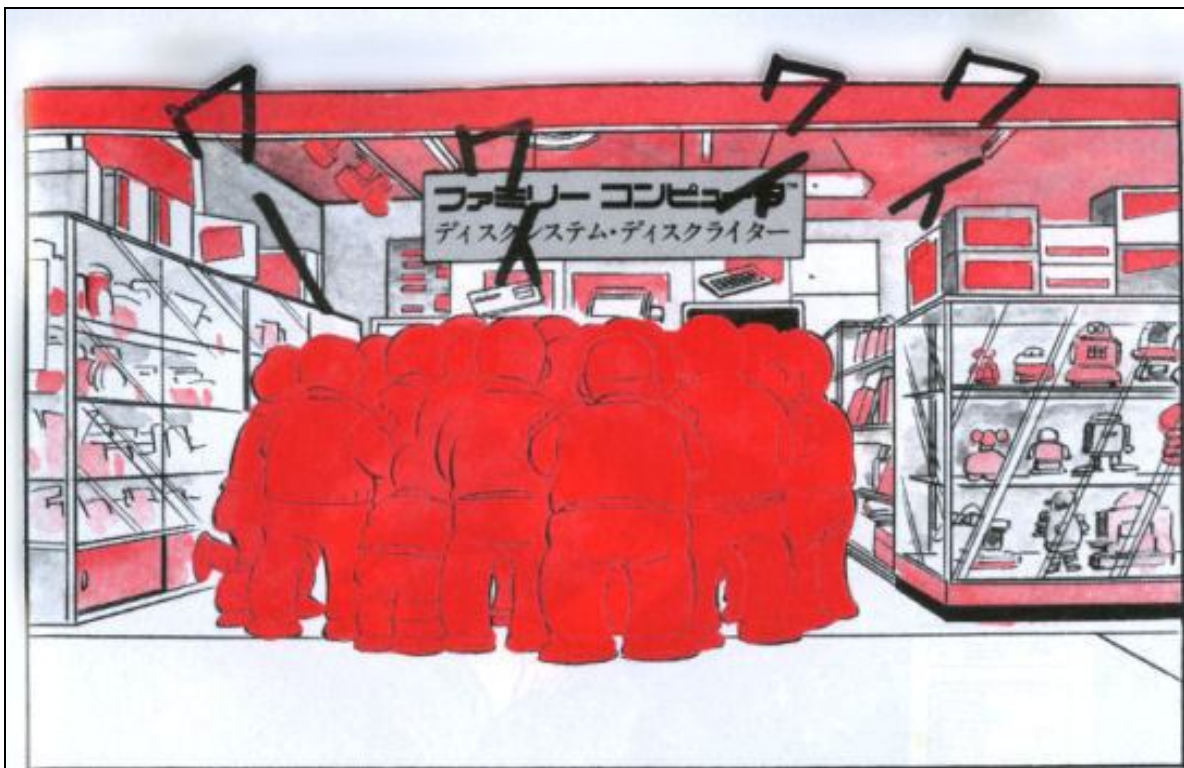

\* KYORO KYORO - THE SOUND OF LOOKING AROUND









\* LRO LRO - SOUND OF WALKING AROUND  
\* JIRO JIRO - SOUND OF STARING

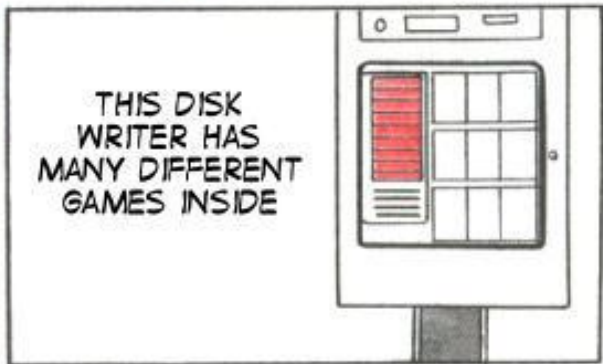



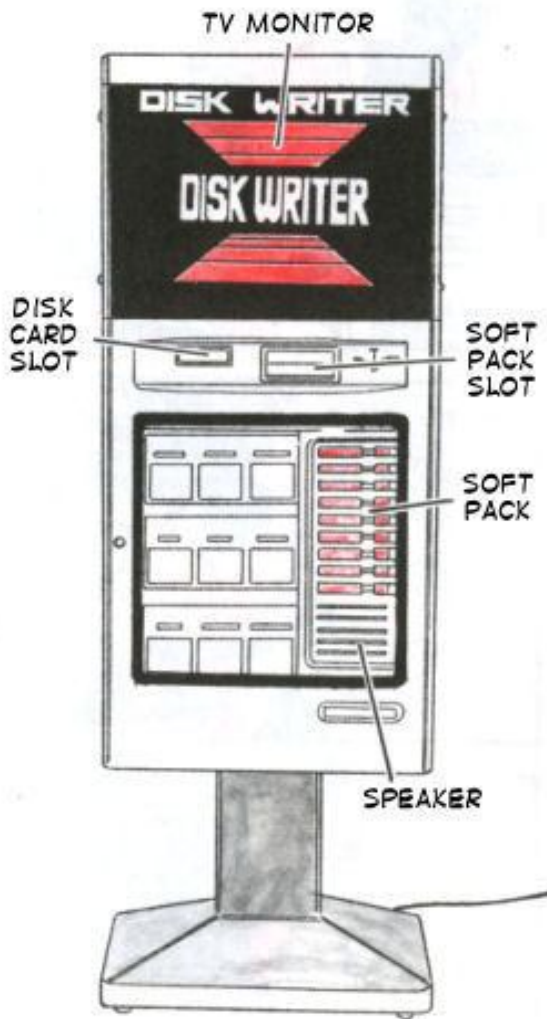

THEREFORE, IF YOU TAKE YOUR DISK CARD TO THE STORE, ANOTHER GAME CAN BE RE-WRITTEN ONTO IT.

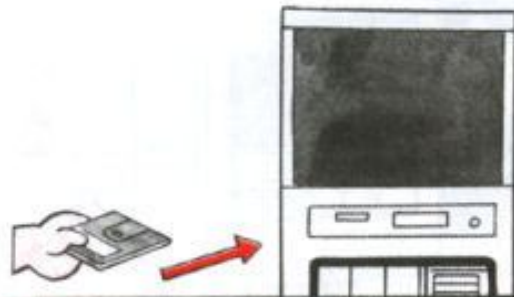

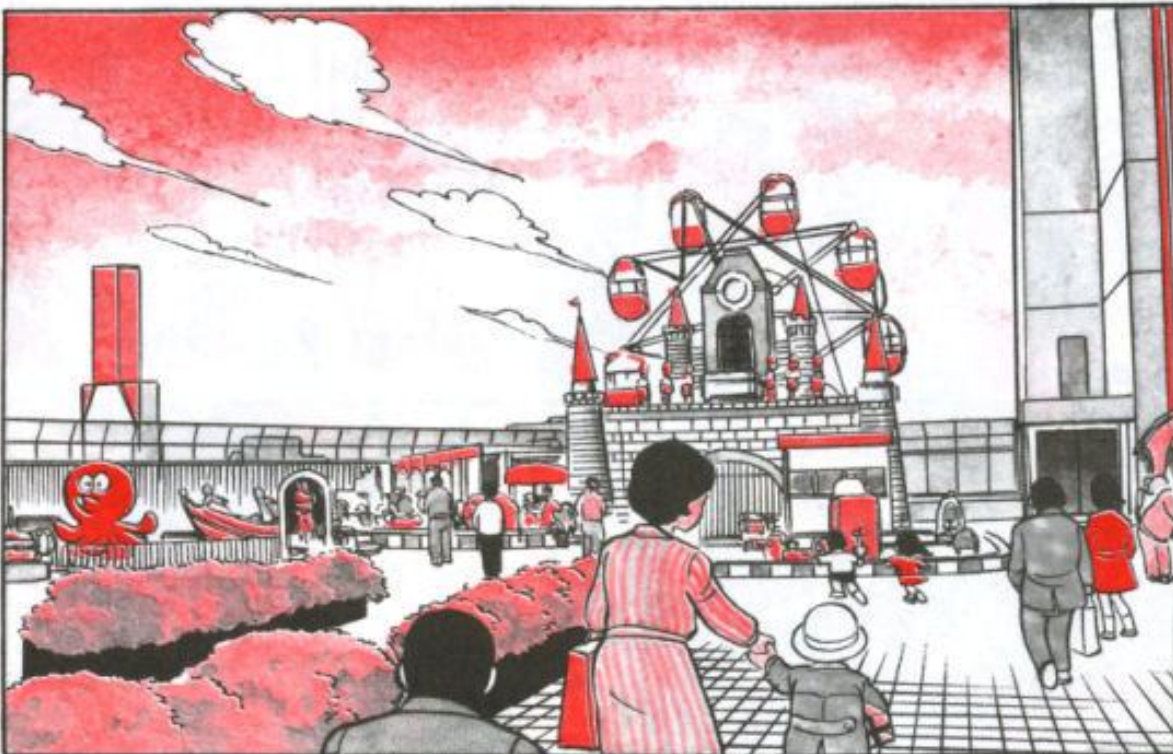
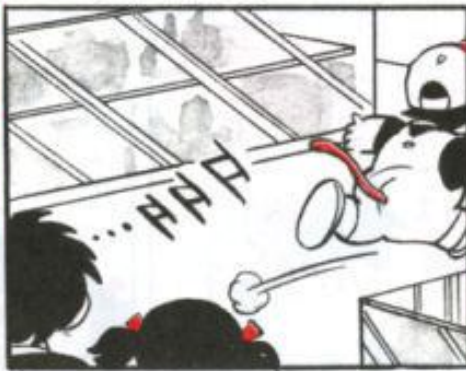



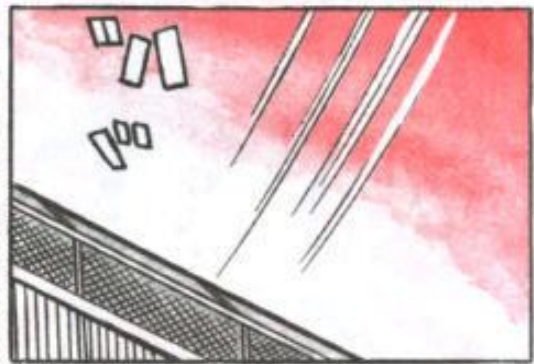



OH,  
WOW!



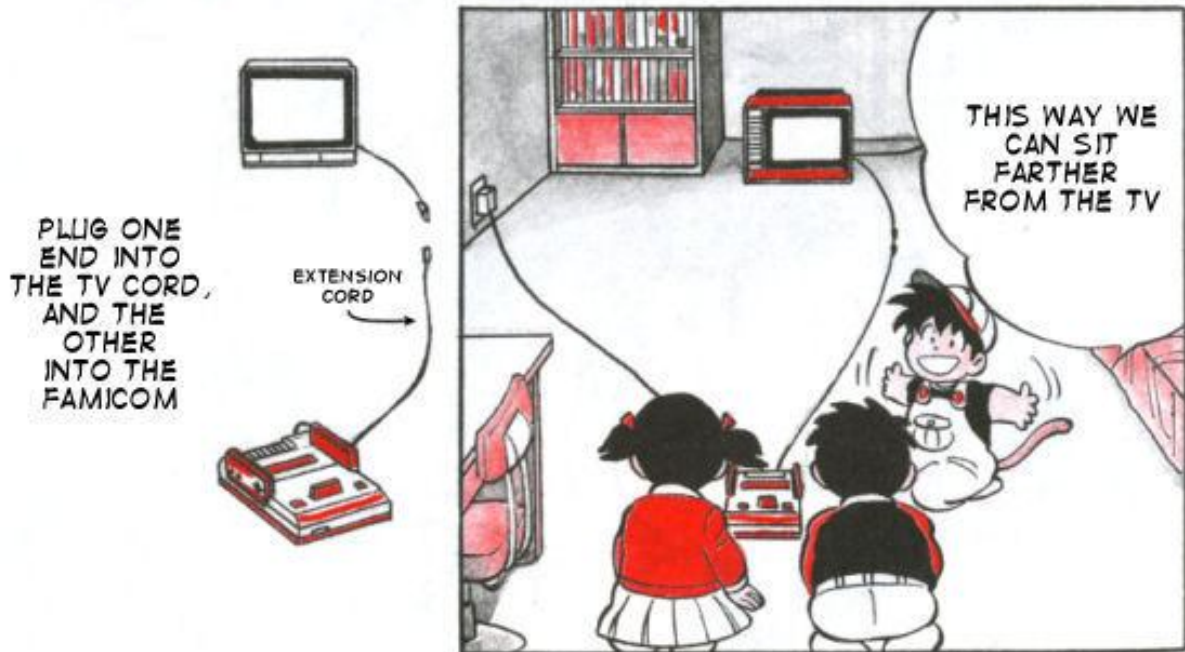



PUT 6  
C-CELL  
BATTERIES  
IN THE  
DRIVE

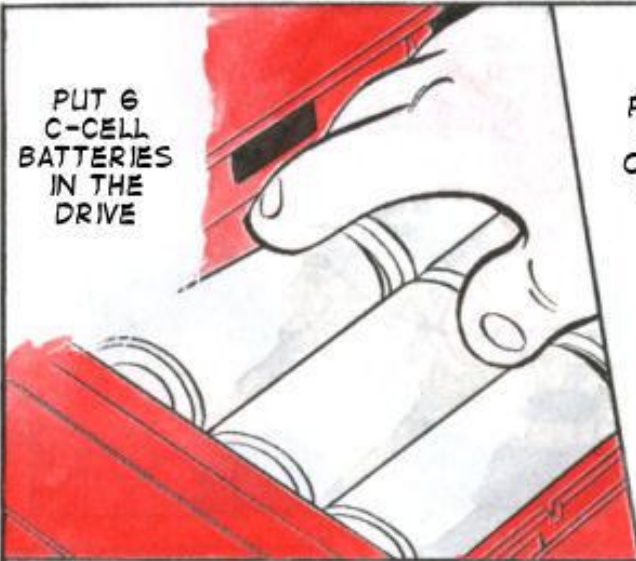

PLACE THE  
SYSTEM  
ON TOP OF  
THE DISK  
DRIVE

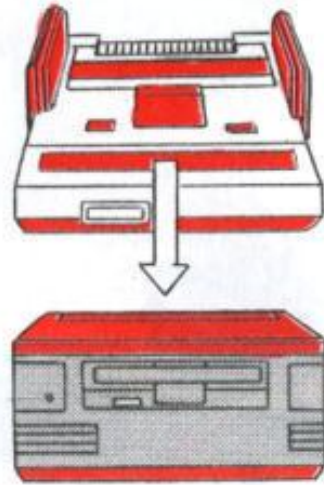

PLACE THE  
RAM ADAPTOR  
SNUGLY IN  
THE 60-PIN  
SLOT

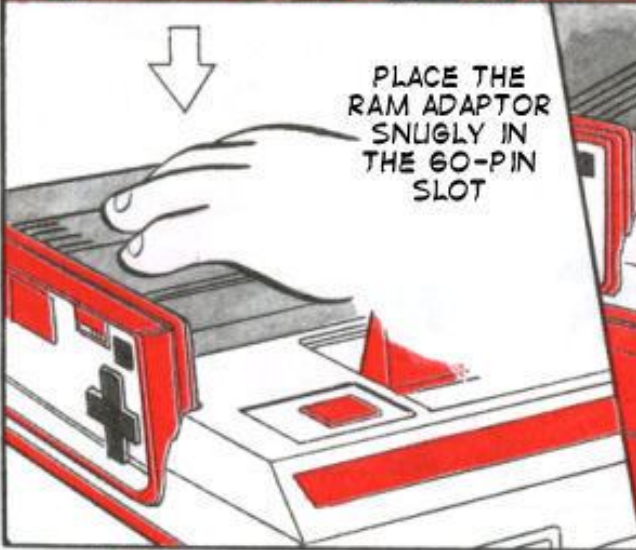

INSERT  
THE PLUG  
FROM THE  
RAM  
ADAPTOR  
INTO THE  
DRIVE

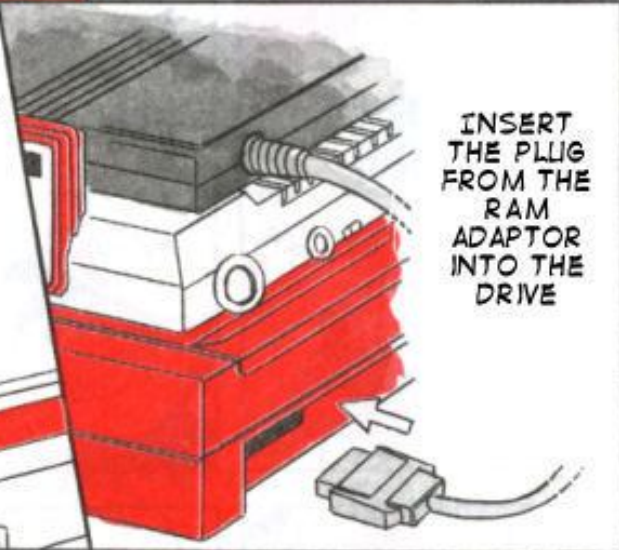

MANABU,  
PLUG THE  
AC ADAPTOR  
INTO THE  
WALL

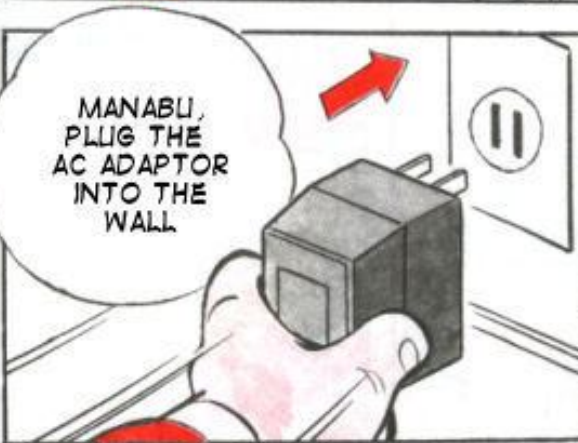

TURN  
ON THE  
FAMICOM

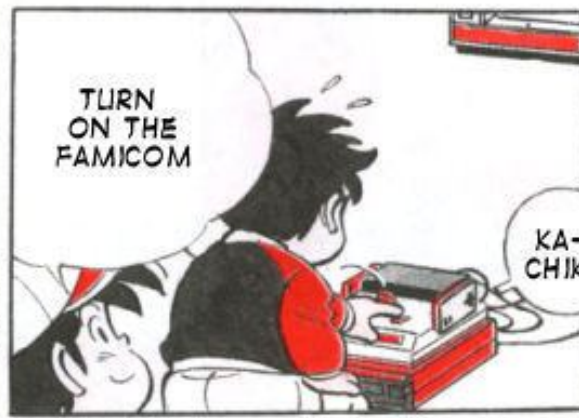

KA-  
CHIK!

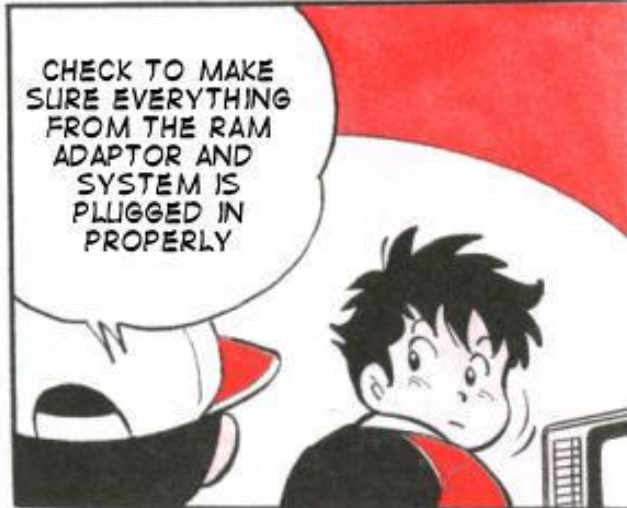
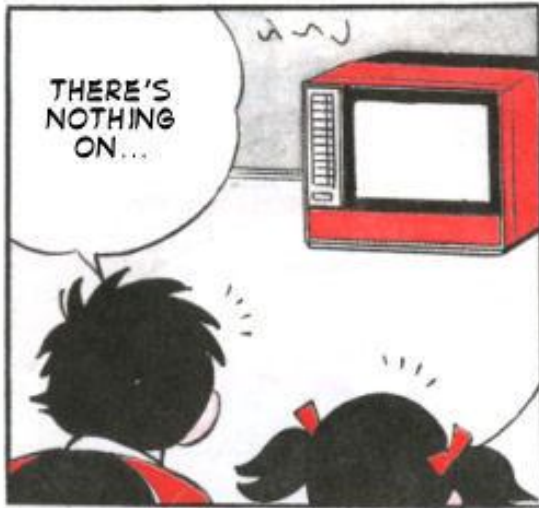

GACHA GACHA = RATTLE & RUSTLE

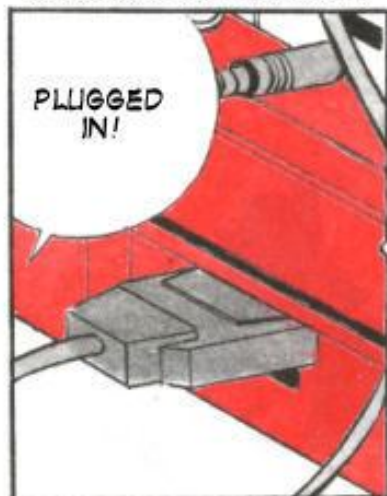





PA-KA! - OPENING CASE SOUND

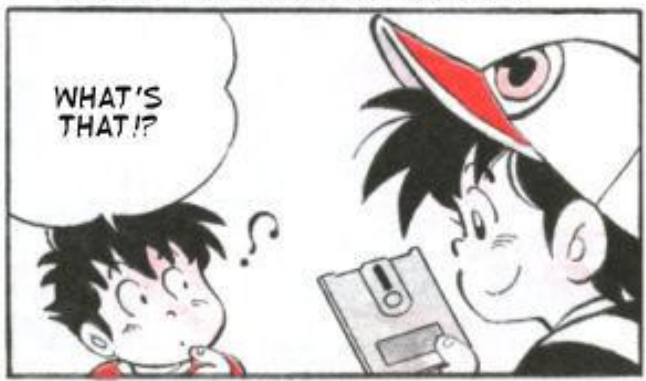
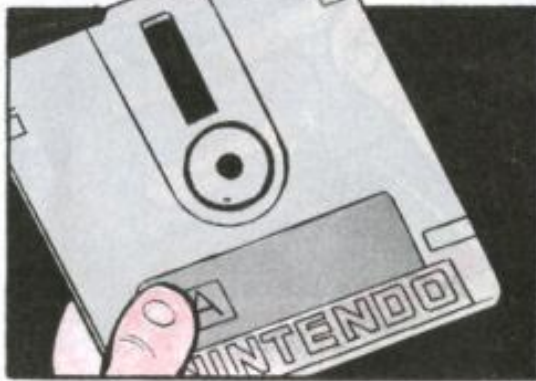

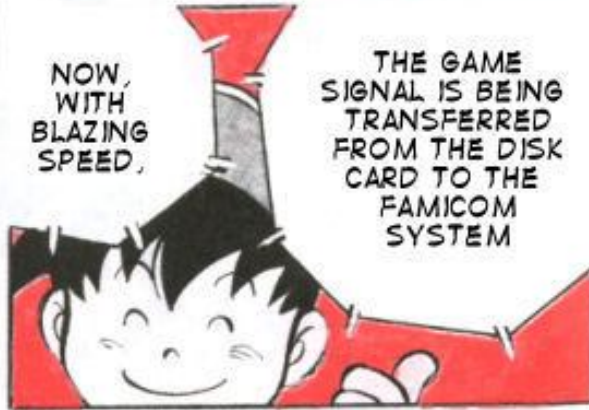
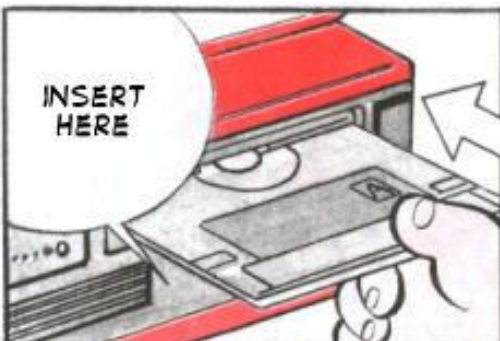
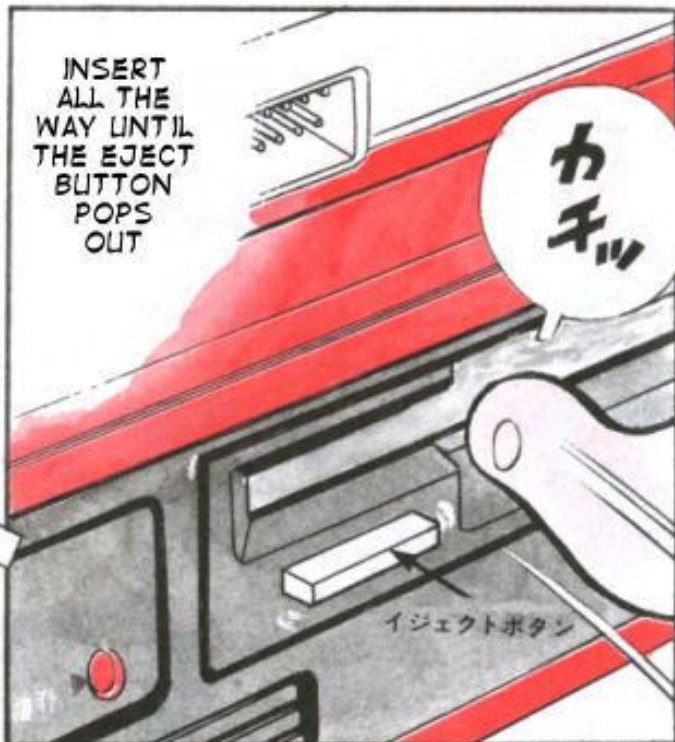
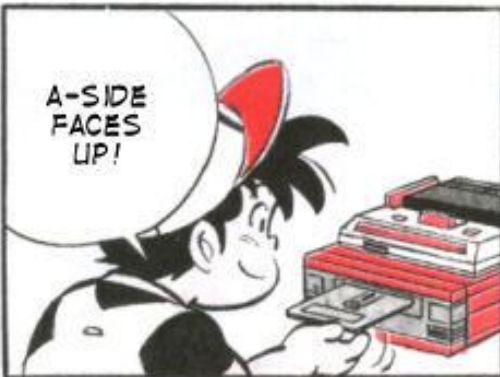



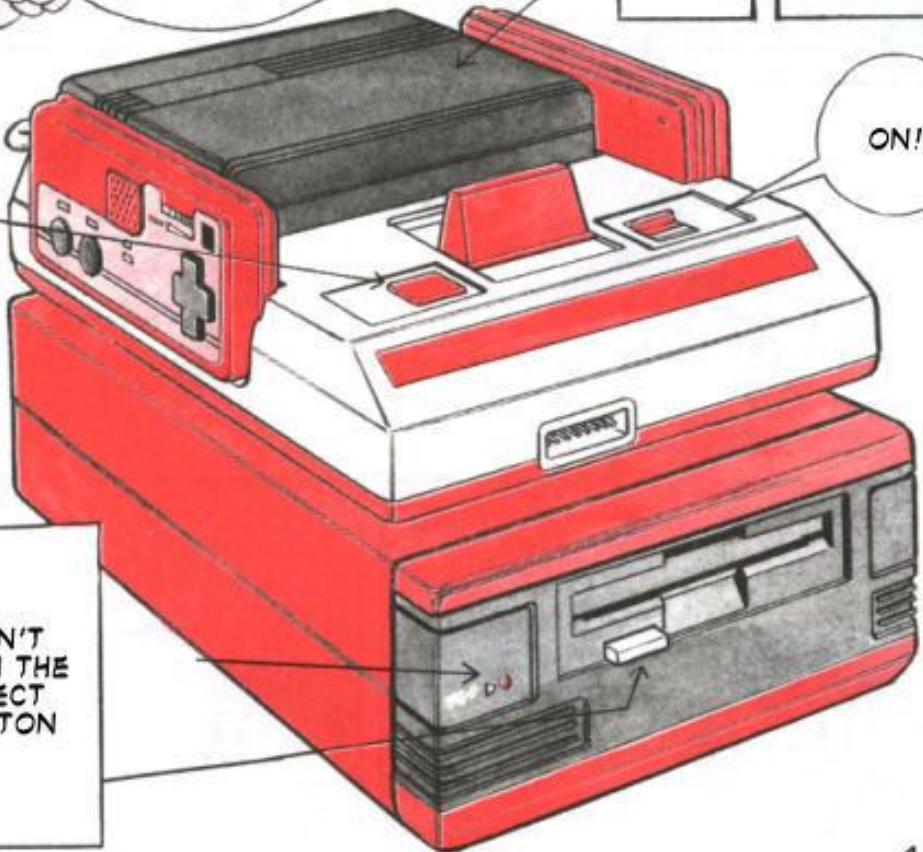
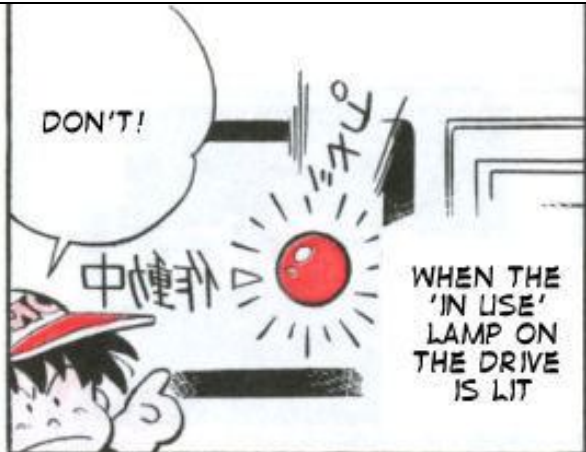







OH,  
A NEW  
GAME?



HEY, CONKICHI!  
NOW THAT TAKASHI  
IS HERE, CAN YOU GO  
OVER THE POINTS  
AGAIN?

YEAH,  
SURE

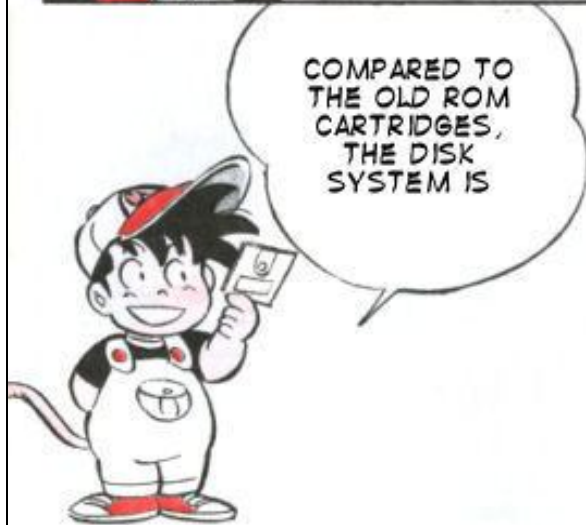

COMPARED TO  
THE OLD ROM  
CARTRIDGES,  
THE DISK  
SYSTEM IS



YOU CAN  
RE-WRITE  
THE GAMES  
WITH THE  
DISK WRITER  
IN STORES

SAYONARA

THE MEMORY  
CAPACITY HAS  
INCREASED,  
ALLOWING  
BETTER  
AND MORE  
SOPHISTICATED  
GAMES

GAMES  
HAVE  
MORE  
DATA!

SOME GAMES  
WILL SAVE  
SCORES AND  
NAMES ON  
THE DISK  
CARD

WOW,  
YOU CAN DO ALL  
SORTS OF  
THINGS

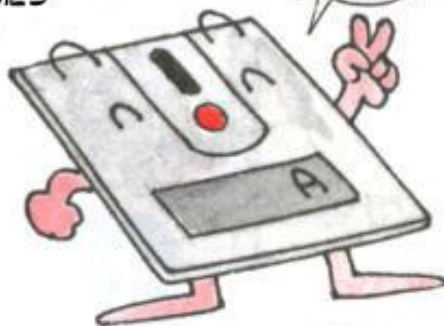

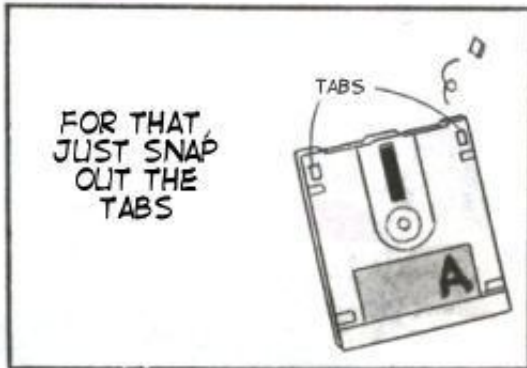





DOKI DOKI - HEART BEATING  
SOWA SOWA - NERVOUS SOUND





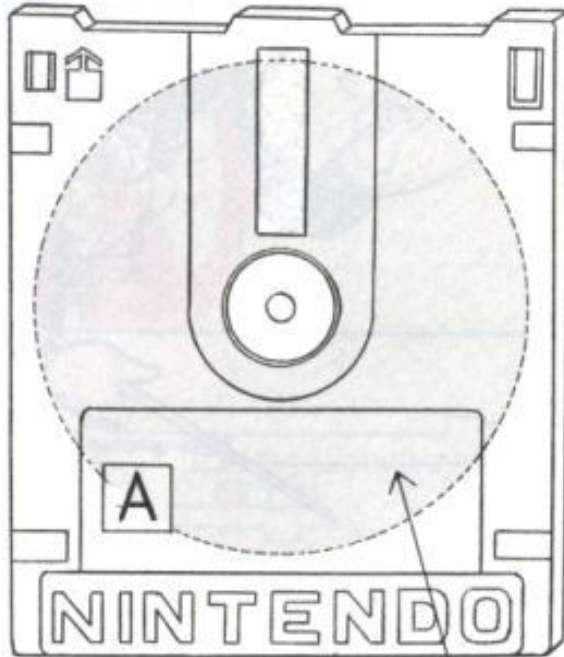

THE DISK CARD IS MADE WITH A PLASTIC DISK COATED WITH A THIN MAGNETIC LAYER.

ELECTRONIC DATA IS RECORDED IN A SPIRAL ON THIS DISK.



MAGNETIC FILM

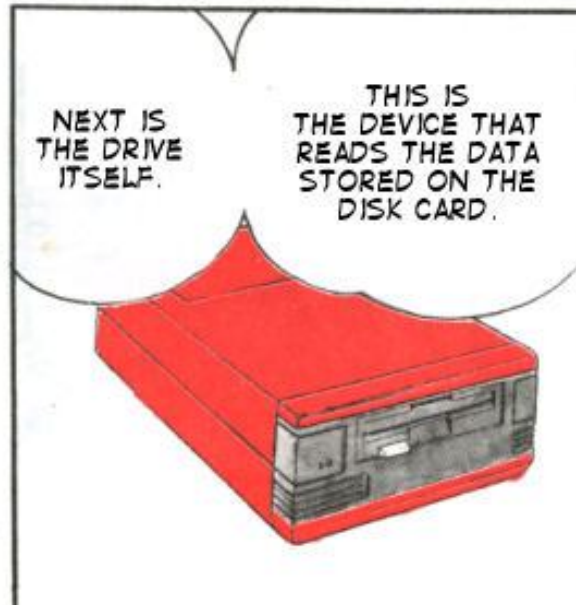



THIS IS THE INSIDE OF YOUR DISK DRIVE



WOW, COOL!

MOTOR

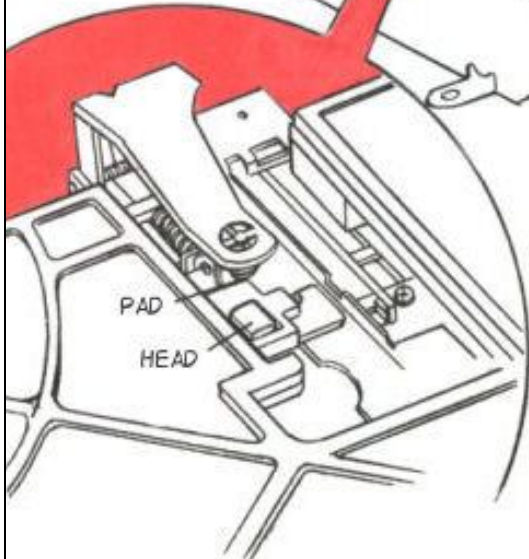
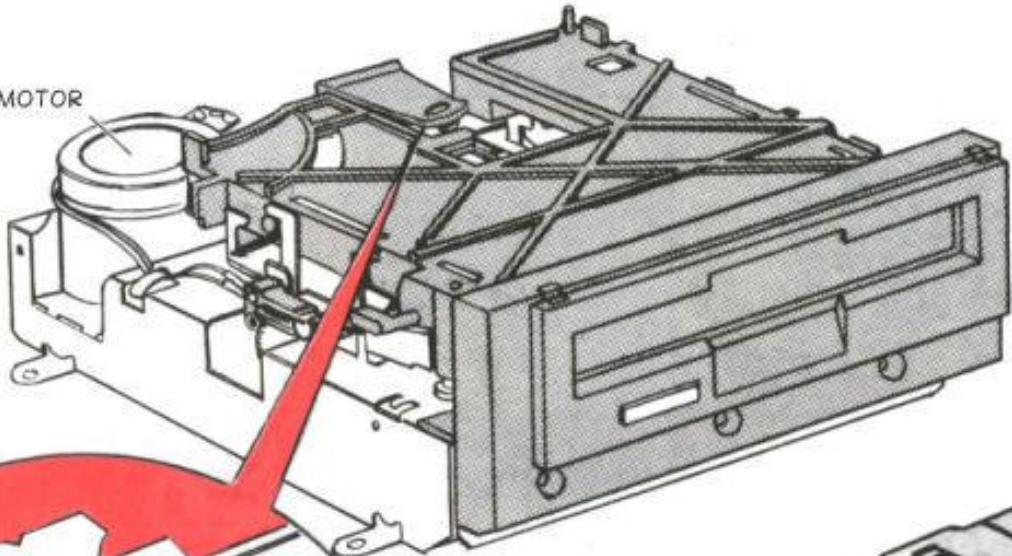

PAD

HEAD

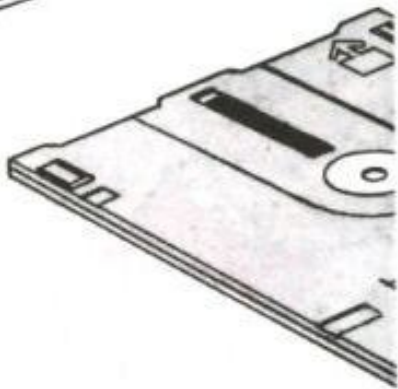

TRANSLATED BY ZUMI & NFG  
NFGGAMES.COM





WHEN YOU INSERT A DISK CARD, THE HEAD PRESSES AGAINST THE MAGNETIC DISK. NEXT THE DISK STARTS TO SPIN, AND THE HEAD FOLLOWS THE SPIRAL, READING THE DATA.

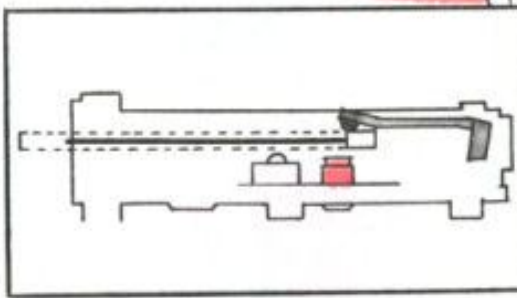
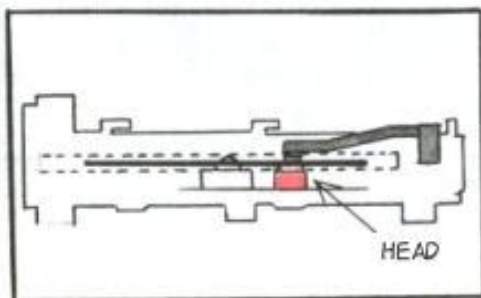

ONCE THE DATA IS READ, IT'S STORED ON THE RAM ADAPTOR



WHEN THE RAM ADAPTOR LOADS ALL THE DATA IT ACTS THE SAME AS A ROM CARTRIDGE.

THE EXPLANATION WAS A LONG ONE, COULD YOU FOLLOW IT?



WE GOT IT!





THIS IS WHAT YOU MEAN, RIGHT?

THE DISK CARD IS LIKE A VINYL RECORD.

THE DISK DRIVE IS LIKE THE RECORD PLAYER.

THE RAM ADAPTOR WORKS THE SAME AS A FAMICOM ROM CARTRIDGE.

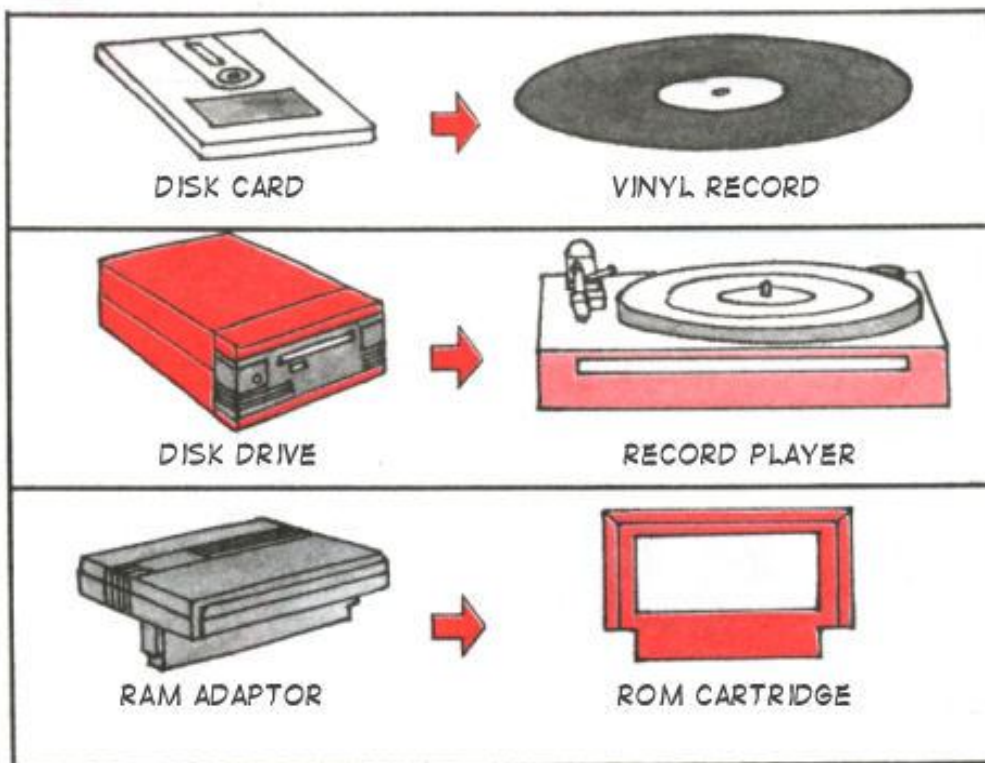

EXACTLY!

KIDS ON EARTH ARE PRETTY CLEVER.



RAM, UNLIKE THE OLD ROM CARTRIDGES, CAN STORE THE GAME DATA

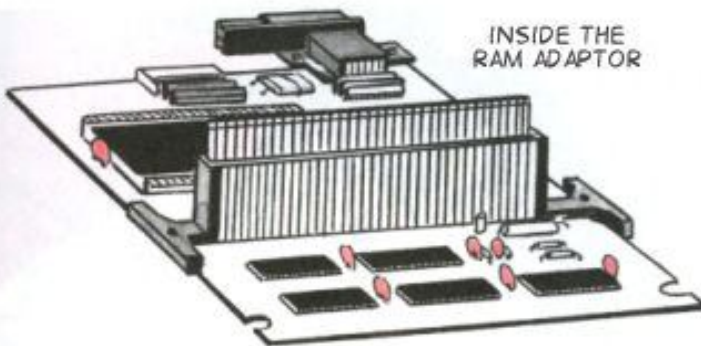
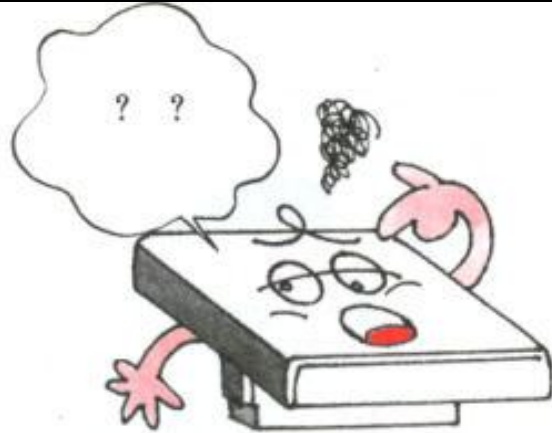

INSIDE THE RAM ADAPTOR

BUT IF YOU TURN OFF THE POWER, THE STORED GAME WILL BE ERASED.



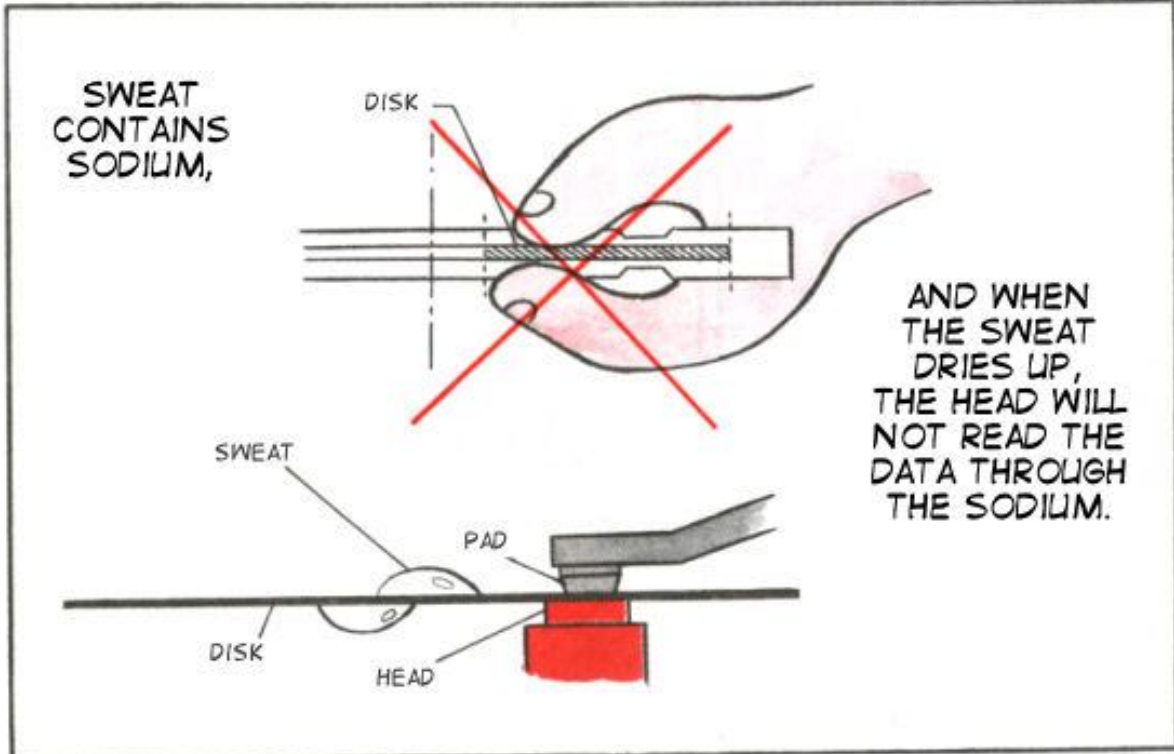



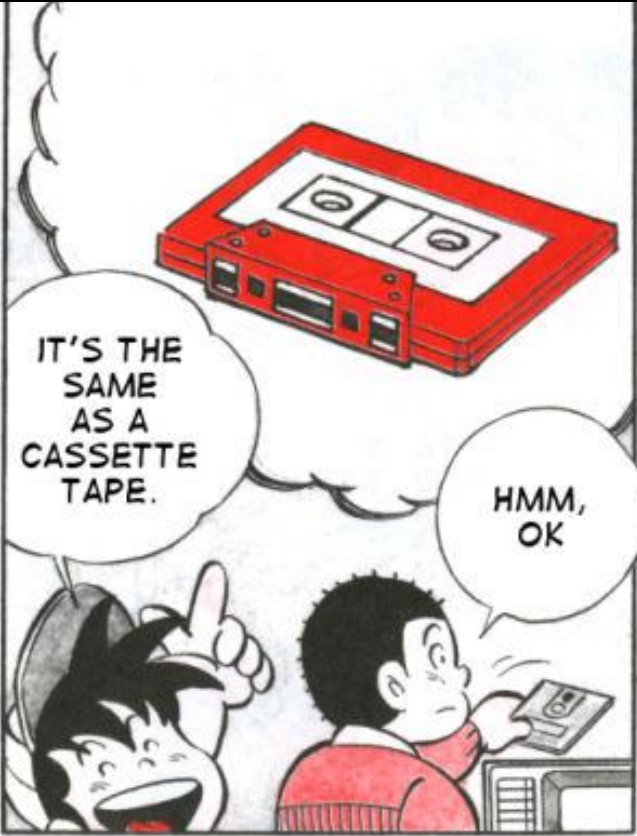



IT'S LIKE THIS!

WHEN YOU PUT IRON POWDER IN AN 'A' SHAPE ON A PLASTIC SHEET,



PLASTIC SHEET

THEN PUT A MAGNET NEAR IT, THE IRON POWDER NEAR THE MAGNET IS REARRANGED.

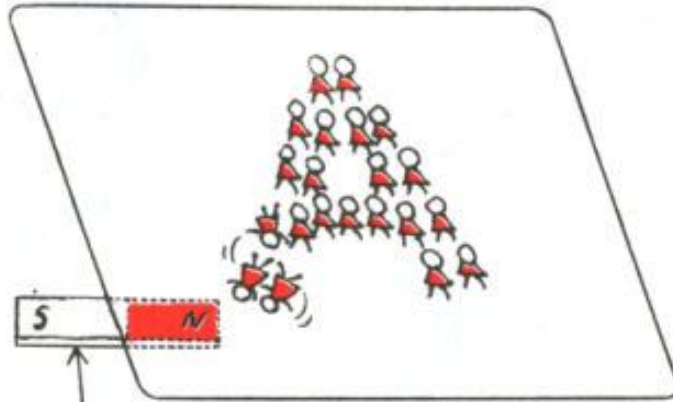

MAGNET



KYOKO-CHAN, YOU'RE SO SMART, LIKE ME!

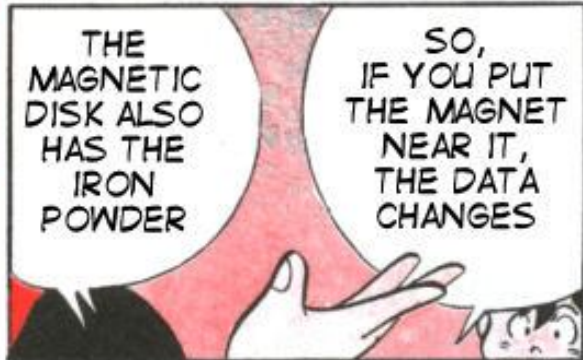

THE MAGNETIC DISK ALSO HAS THE IRON POWDER

SO, IF YOU PUT THE MAGNET NEAR IT, THE DATA CHANGES



ALSO,  
YOU SHOULD  
NOT LET  
DISK CARD  
GET HOT

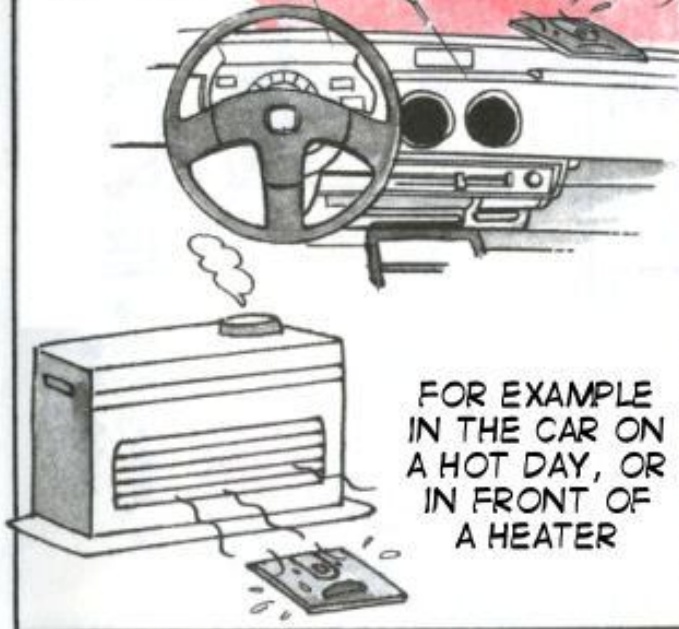

FOR EXAMPLE  
IN THE CAR ON  
A HOT DAY, OR  
IN FRONT OF  
A HEATER

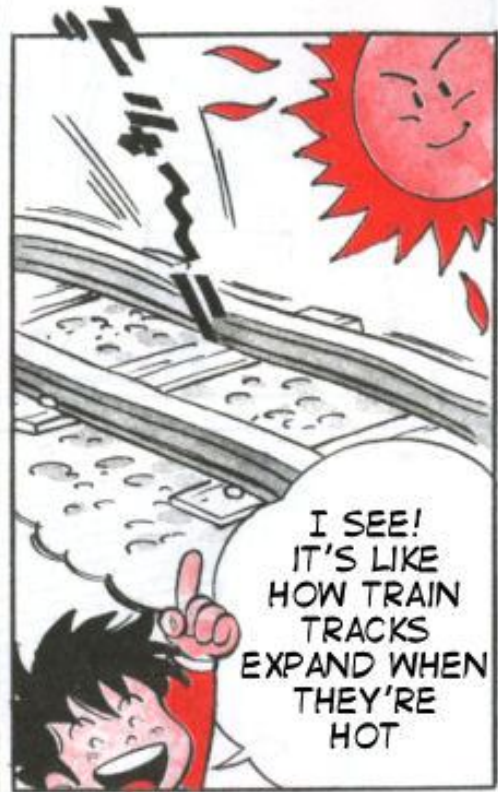

I SEE!  
IT'S LIKE  
HOW TRAIN  
TRACKS  
EXPAND WHEN  
THEY'RE  
HOT

YES,  
ESPECIALLY  
OVER SIXTY  
DEGREES  
CELCIUS.  
IT WON'T  
WORK  
AFTER  
THAT



YOU  
SHOULD ALSO  
AVOID COLD  
PLACES

DO YOU  
KNOW WHAT  
CONDENSATION  
IS, MANABU?



NO...

IT'S WHEN  
GLASSES  
FOG UP  
LIKE  
EARLIER



EXACTLY!



HUMID AND STEAMY PLACES



WHEN BRINGING THE DISK CARD INSIDE FROM THE COLD, INTO WARM AIR



IN A COLD BREEZE, NEAR AN AIR-CON

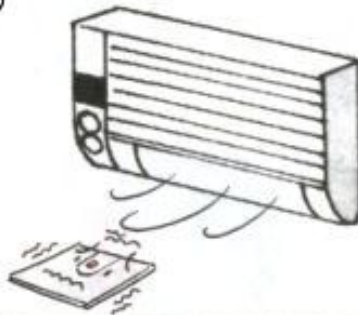

IN THESE CASES, CONDENSATION CAN OCCUR

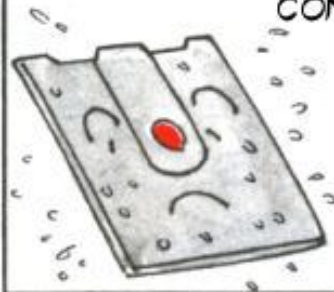

DRY THE MAGNETIC DISK BEFORE USING IT, IF YOU SEE MOISTURE ON IT

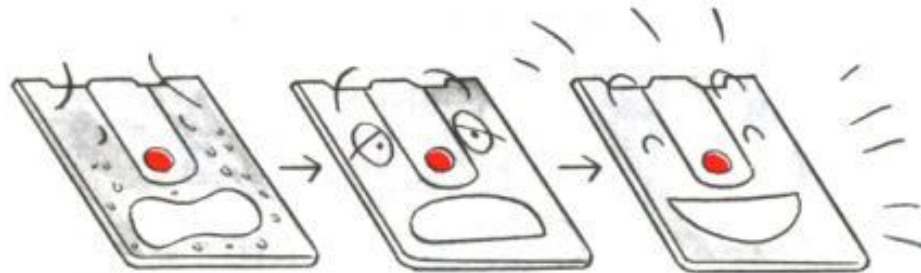

IS THIS DISK DRIVE DURABLE?

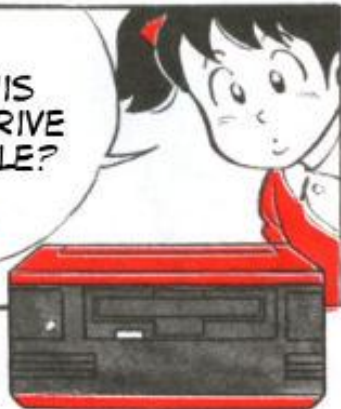

IT'S WEAK AGAINST VIBRATION

SO DON'T MOVE IT WHEN IT'S POWERED ON

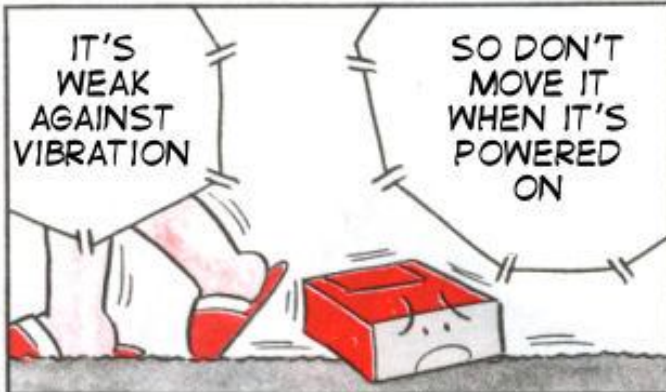



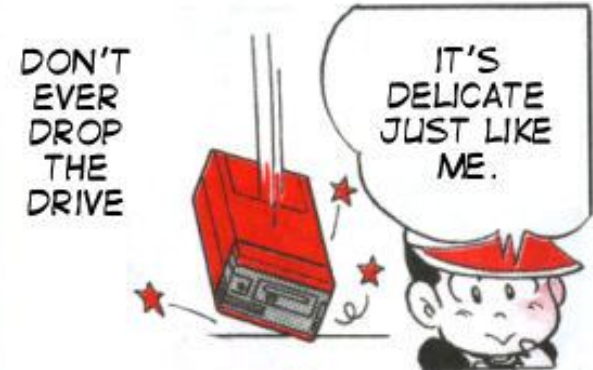





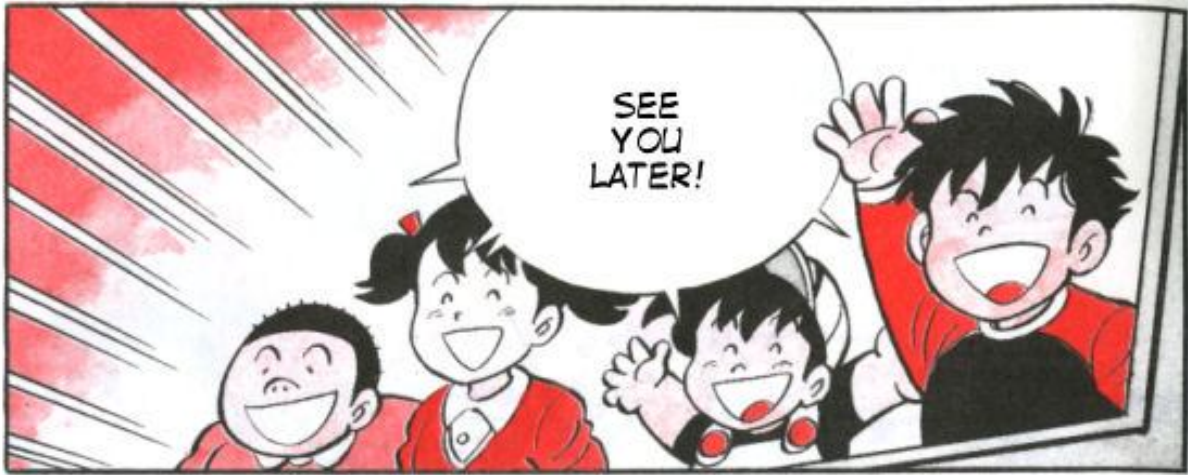



ALWAYS  
KEEP THESE  
THINGS IN  
MIND

DON'T TOUCH THE  
MAGNETIC  
DISK ①



DON'T LET ②  
THE DISK  
GET TOO  
HOT OR COLD



DON'T LEAVE ③  
THE DISK CARD  
NEAR MAGNETS  
LIKE THE TV OR RADIO

YOU SHOULD  
ALSO AVOID  
MAGNETS AND  
ELECTRIC KEYS



DON'T DROP OR STEP ④  
ON THE DISK CARD



WATCH OUT FOR ⑤  
CONDENSATION



ALWAYS STORE ⑥  
THE DISK CARD  
IN THE CASE

